



---

## Technical data sheet

Dehumidifiers

---

# Contents

DESCRIPTION	3
ADVANTAGES	3
Neutral air dehumidification version (isothermal)	3
Version for dehumidification and integration in cooling (and heating)	4
EXTERNAL WALL AND RECESSED WALL DEHUMIDIFIER	4
PERFORMANCES (EXTERNAL WALL AND RECESSED WALL )	4
EXTERNAL UNIT	5
RECESSED WALL UNIT	7
CASE	8
CLADDING FRONT PANELS	8
CEILING DEHUMIDIFIERS	9
PERFORMANCES (CEILING)	9
Ceiling dehumidifiers: dimensions	10
DEHUMIDIFIER CONTROL PANEL	11
Modbus RS485 remote wall panel	12
Electronic remote wall panel	12

## Dehumidifiers

Dehumidifiers are used to reduce excess humidity in the air of a room. The ideal humidity level for human comfort is between 40% and 60%. When levels exceed this threshold, various problems can arise. Dehumidifiers improve living comfort, prevent mould growth and make the air healthier. General Fittings offers wall-mounted and false ceiling installation solutions.

### DESCRIPTION

General Fittings offers a range of wall, recessed wall or ceiling mounted dehumidifiers that can dehumidify indoor air, thus ensuring a healthy environment and high physical well-being.

General Fittings offers air treatment units that help to increase the air temperature in the winter season and decrease it in the summer season by regulating the air humidity.

They can operate without the aid of pre- and post-cooling water coils (dehumidifiers in neutral air version): this is very useful when dehumidification is required in the intermediate seasons and the chiller is switched off.

### ADVANTAGES

- Humidity control: a dehumidifier is the perfect solution against excess humidity in the home, improving physical well-being and thermal/energetic comfort
- Prevents the formation of mould: one of the most common effects of excess humidity in the home. Placing a dehumidifier in the room will reduce the moisture in the air and the possibility of mould growth.

### Neutral air dehumidification version (isothermal)

Unit for dehumidifying only the air coming from the EC recirculation fan, thus allowing the cooling circuit to operate, obtaining dehumidified air during the summer period (compressor active).

Equipped with a hydronic pre- and post-cooling/heating coil that, when powered, provides cooling/heating power supplement to the radiant cooling system (connection to the heating/cooling system is optional and does not affect air dehumidification).

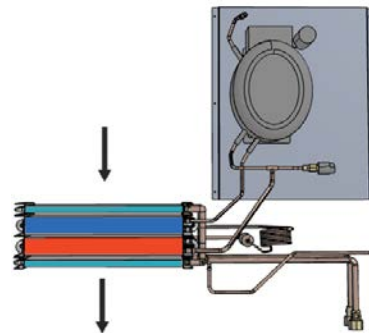

## Version for dehumidification and integration in cooling (and heating)

Unit for dehumidifying the air from the recirculating EC fan allowing integration of cooling/heating power to the radiant cooling system.

During the summer period (compressor active) the unit can operate in 2 modes:

- Dehumidification: the unit condenses partly in air and partly in water via the plate condenser, resulting in dehumidified air;
- Dehumidifying + Cooling Integration: the unit condenses totally in water, thus obtaining dehumidified and cooled air.

During the winter period (compressor off) the hydronic coils are supplied with hot water from the heating system and behave like a fan coil.

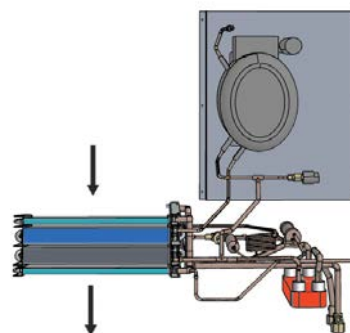

## EXTERNAL WALL AND RECESSED WALL DEHUMIDIFIER

Dehumidifier for radiant systems with air treatment section with dehumidification, cooling and heating. The unit is particularly suitable for residential, commercial (small size) or collective residential buildings and is supplied plug-and-play for quick and easy installation.

The unit consists of a monoblock including every component for correct operation and allows operation with wide outdoor temperature ranges and in combination with radiant systems.

Available in one size, with a variable flow rate from 320 m<sup>3</sup>/h to 500 m<sup>3</sup>/h, both in the neutral air version and with integration.

## PERFORMANCES (EXTERNAL WALL AND RECESSED WALL )

### GENERAL TECHNICAL DATA

Electric supply	V/Ph/Hz	230/1/50
IP protection rating	IP	20
Maximum air flow rate	m <sup>3</sup> /h	500
Nominal air flow rate	m <sup>3</sup> /h	320
Nominal working pressure	Pa	50
Max. useful pressure	Pa	70

### NEUTRAL AIR VERSION

Effective dehumidification capacity	l/24h	18
-------------------------------------	-------	----

### NEUTRAL AIR VERSION

Cooling capacity hydronic coil output <sup>2</sup>	kW	1.25
Thermal power output <sup>3</sup>	kW	1.1
Water flow rate	m <sup>3</sup> /h	0.22
Pressure drop	Kpa	5.2
Sound pressure Lp at 3 Mt	dB(A)	35
Power supply	V/Ph/Hz	230 / 1 / 50
Maximum absorbed current versions R	A	4.2
(2) Ambient temperature 26 °C; relative humidity 65%; nominal air flow; water 7/12 °C (IN/OUT);		
(3) Ambient temperature 20 °C; relative humidity 50%, nominal air flow; water 45/40 °C (IN/OUT);		

### VERSION WITH INTEGRATION

Effective dehumidification capacity	l/24h	18
Cooling capacity hydronic coil output <sup>2</sup>	kW	1,25
Total compressor output cooling capacity <sup>2</sup>	kW	1,35
Sensible compressor output cooling capacity <sup>2</sup>	kW	0.86
Thermal power output <sup>3</sup>	kW	1,10
Water flow rate	m <sup>3</sup> /h	0.22
Pressure drop	Kpa	5.2
Sound pressure Lp at 3 Mt	dB(A)	35
Power supply	V/Ph/Hz	230 / 1 / 50
Maximum absorbed current versions R	A	4.2
(2) Ambient temperature 26 °C; relative humidity 65%; nominal air flow; water 7/12 °C (IN/OUT);		
(3) Ambient temperature 20 °C; relative humidity 50%, nominal air flow; water 45/40 °C (IN/OUT);		

## EXTERNAL UNIT

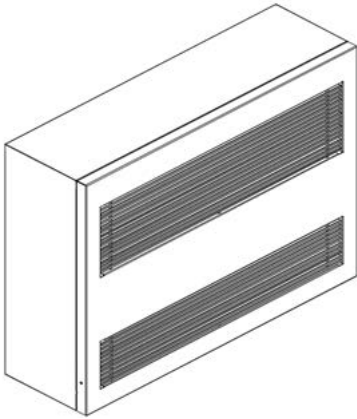

## DIMENSIONS

Width A	mm	790
Depth B	mm	240
Height C	mm	650
Water supply/return connections	Ø	1/2" - 1/2"
Condensation	Ø	16 mm
Neutral air version weight	kg	40
Integration version weight	kg	42

## RECESSED WALL UNIT

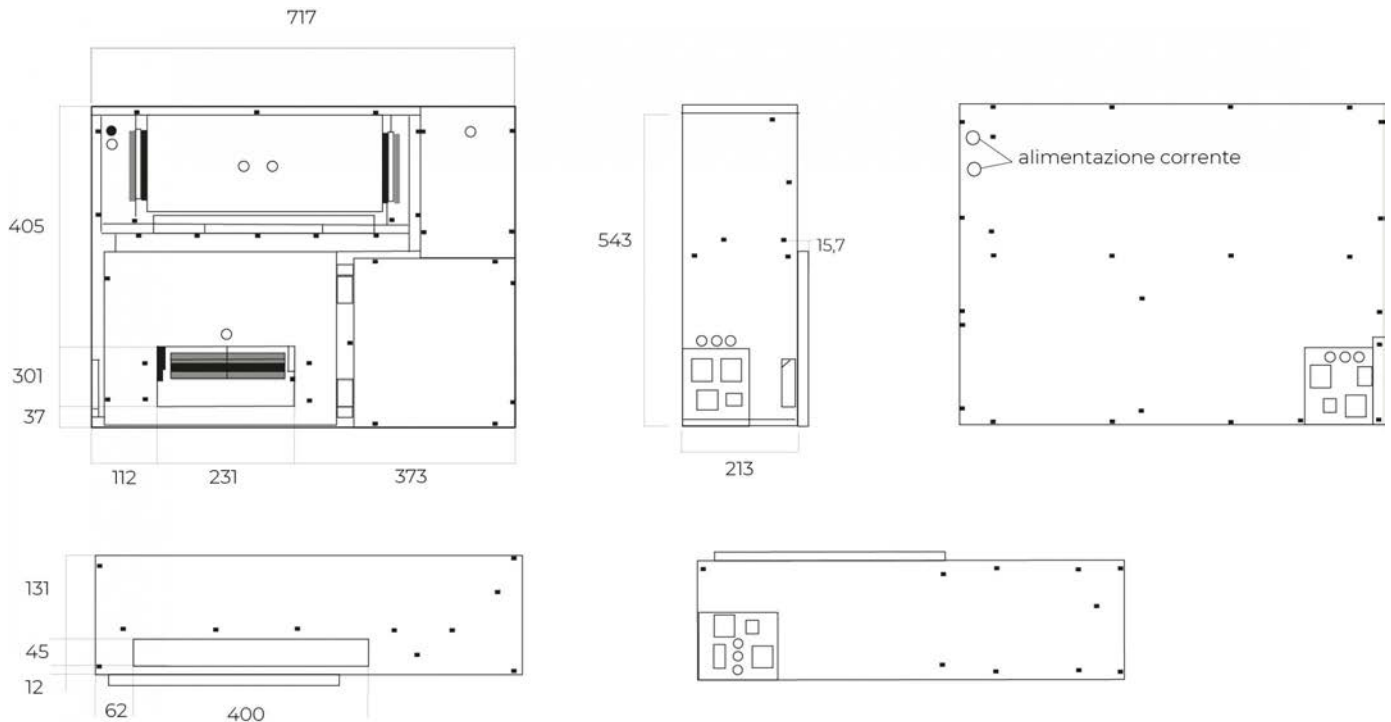

### DIMENSIONS

Width A	mm	717
Height B	mm	543
Depth C	mm	213
Front delivery b x h	mm	400 x 195
Ducted top outlet	mm	400 x 120
Suction	mm	340 x 210
Water supply/return connections	$\varnothing$	1/2" - 1/2"
Condensation	$\varnothing$	16 mm
Weight	kg	31

CASE

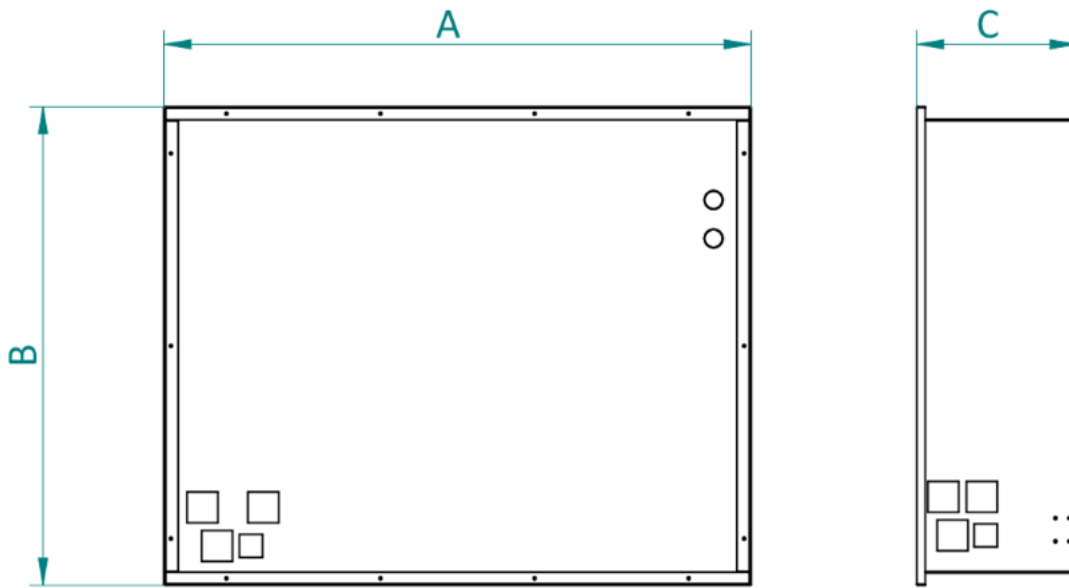

DIMENSIONS		
Width A	mm	761
Height B	mm	621
Depth C	mm	208
Weight	kg	31

S

CLADDING FRONT PANELS

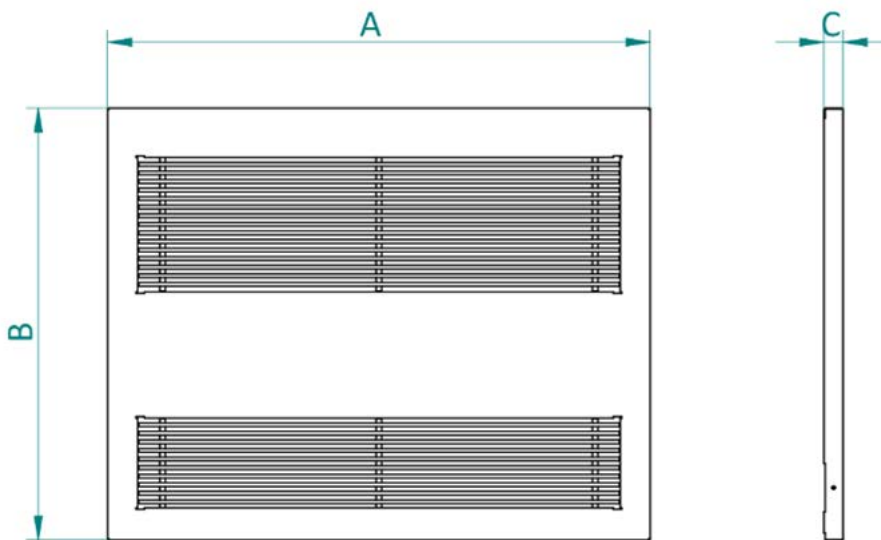

#### DIMENSIONS

Width A	mm	790
Height B	mm	630
Depth C	mm	28
Weight	kg	31

S

## CEILING DEHUMIDIFIERS

Dehumidifier for radiant systems with air treatment section with dehumidification, cooling and heating. The unit is particularly suitable for residential, commercial (small size) or collective residential buildings and is supplied plug-and-play for quick and easy installation.

The unit consists of a monoblock including every component for correct operation and allows operation with wide outdoor temperature ranges and in combination with radiant systems.

Available in two sizes, with a flow rate of 320 m<sup>3</sup>/h and 500 m<sup>3</sup>/h, both in the neutral air version and with integration.

## PERFORMANCES (CEILING)

GENERAL TECHNICAL DATA		300	500
Electric supply	V/Ph/Hz	230/1/50	
IP protection rating	IP	20	
Air flow rate	m <sup>3</sup> /h	300	500
Useful pressure	Pa	150	98

S

NEUTRAL AIR VERSION		300	500
Effective dehumidification capacity	l/24h	18.9	36.2
Cooling capacity hydronic coil output <sup>2</sup>	kW	0.58	1.22
Thermal power output <sup>3</sup>	kW	0.62	1.3
Water flow rate	m <sup>3</sup> /h	0.15	0.3
Pressure drop	Kpa	4.5	9
Sound pressure Lp at 3 Mt	dB(A)	36	38
(2) Ambient temperature 26°C; relative humidity 50%, nominal air flow; water in 16°C;			
(3) Ambient temperature 20°C; relative humidity 60%, nominal air flow; water in 35°C;			

VERSION WITH INTEGRATION		300	500
Effective dehumidification capacity	l/24h	18.9	36.2
Sensible cooling capacity	kW	0.77	1.44
Total output cooling capacity	kW	1.27	2.39
Thermal power output <sup>3</sup>	kW	0.62	1.3
Water flow rate	m <sup>3</sup> /h	0.15	0.3
Pressure drop	Kpa	4.5	9
Sound pressure Lp at 3 Mt	dB(A)	36	38
(2) Ambient temperature 26°C; relative humidity 50%, nominal air flow; water in 16°C;			
(3) Ambient temperature 20°C; relative humidity 60%, nominal air flow; water in 35°C;			

## Ceiling dehumidifiers: dimensions

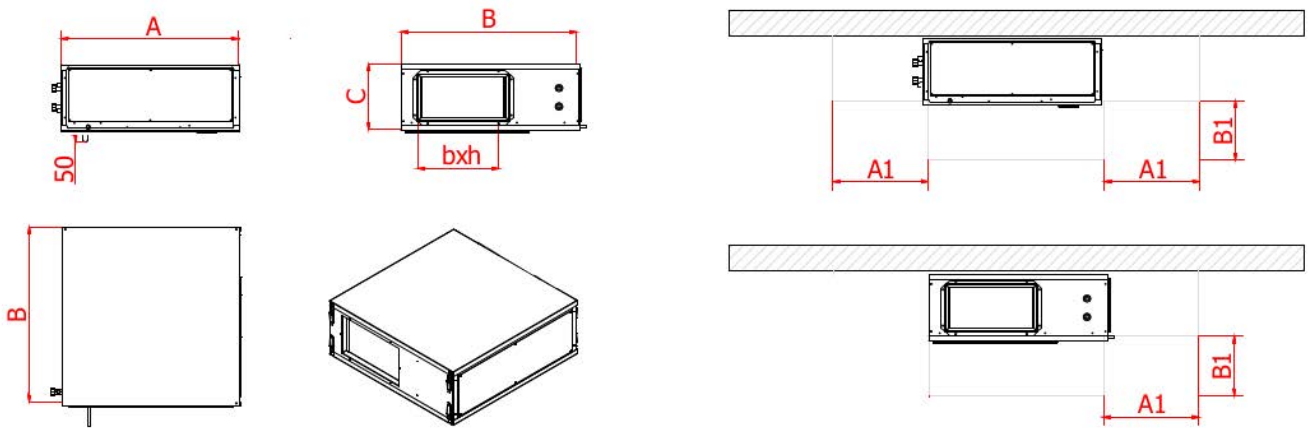

Model		300	500
Width A	mm	690	
Depth B	mm	690	800
Height C	mm	250	310
Delivery bxh	mm	350x180	520x250
(valid for delivery and suction)			
A1	mm	300	
B1	mm	270	320
Water supply/return connections	∅	1/2" - 1/2"	
Condensation	∅	16 mm	
Neutral air version weight	kg	40	53
Integration version weight	kg	42	55
UNIT SEEN FROM ABOVE			

## DEHUMIDIFIER CONTROL PANEL

For the control of dehumidifiers we have two possibilities:

Full control with multiple functions: Modbus digital remote panel



Control with basic functions: electronic remote panel



## Modbus RS485 remote wall panel

The unit provides for autonomous operation via the remote digital control panel that houses the temperature/humidity probe. Functions can be activated by setting temperature/humidity set points and fan speed.

The unit can also be controlled via Modbus RS485 always present on the unit (which also acts as a power supply); through serial communication from an external Master device, it will be possible to activate and modify all the functions of the unit.

Modbus can be managed in two configurations:

1. provides modbus command directly to the unit;
2. provides that the unit has the T/H panel connected for stand-alone operation and the modbus communicates directly with the T/H remote panel.

## Electronic remote wall panel

Daily electronic humidistat that allows you to adjust the humidity at will and change it later with ease. Avoid wasting energy by running the air conditioning or dehumidification system only when needed. Can be installed directly on a 3-module flush-mounting box or on a wall. Battery powered.



GENERAL FITTINGS SPA

Via Golgi 73/75, 25064 Gussago (BS) - ITALY

te. +39 030 3739017

[www.generalfittings.it](http://www.generalfittings.it)